

1

1a

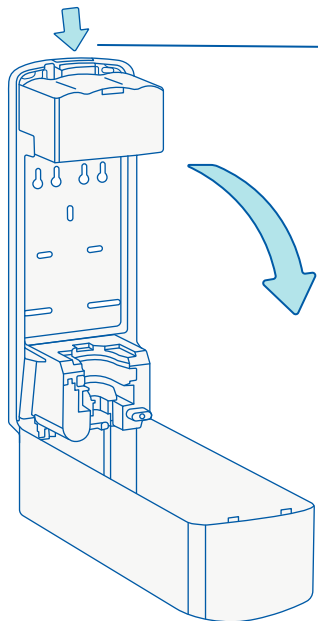

1b

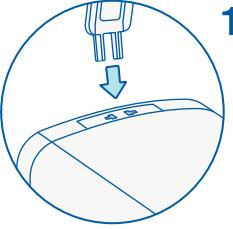

1a. Default orders not locked, push button and open.

1b. Special Order arrived locked, use key push button and open.



Fixing Set

1c

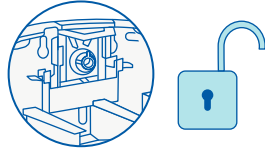
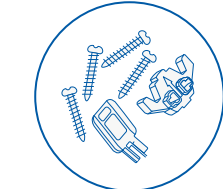
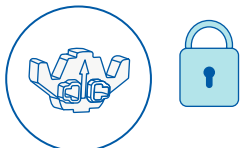
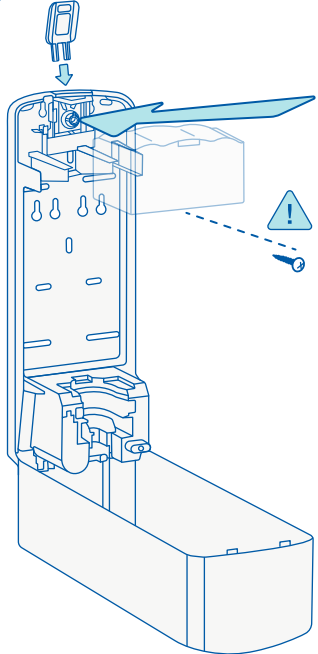

2

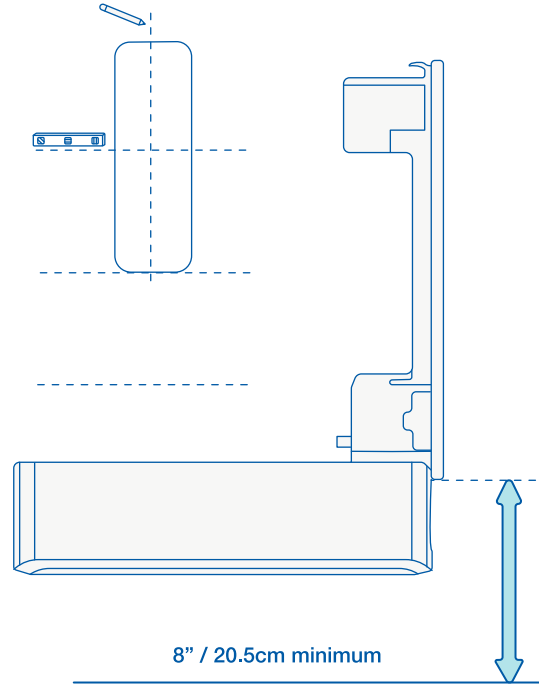

8" / 20.5cm minimum

3

3a

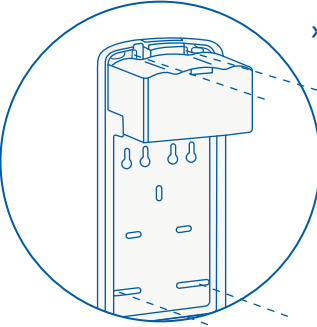

x4

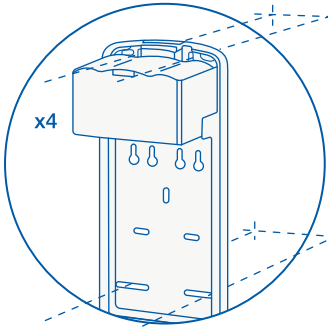

x4



x4

3b

Alcohol Pad

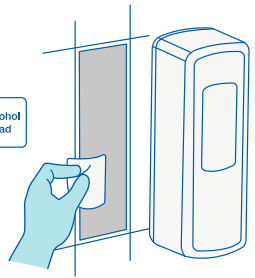

Dry



Seconds

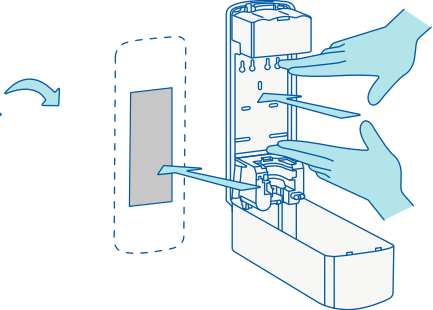
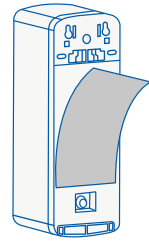

Push + Hold



Seconds

4

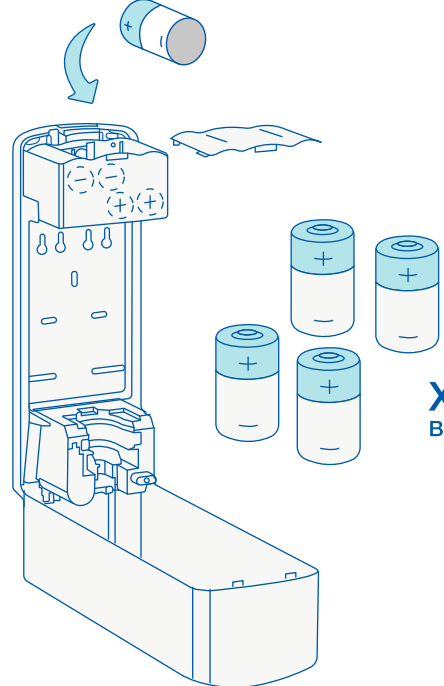

X4 D Batteries

5

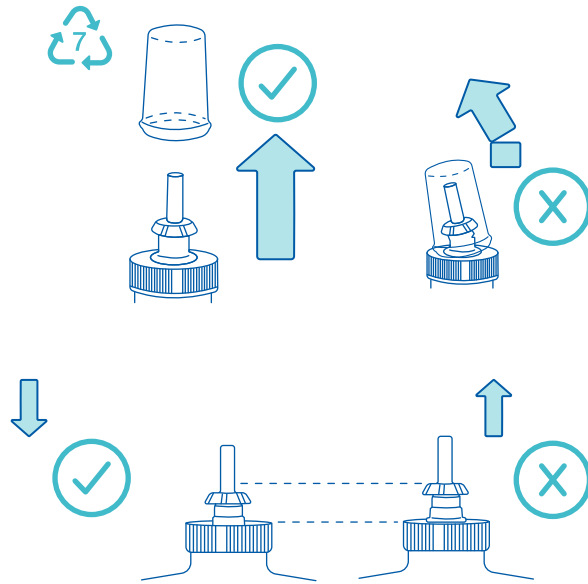

6

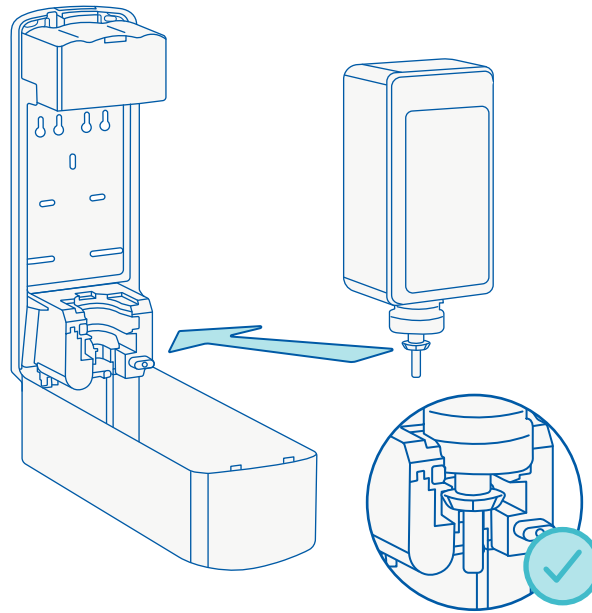

7

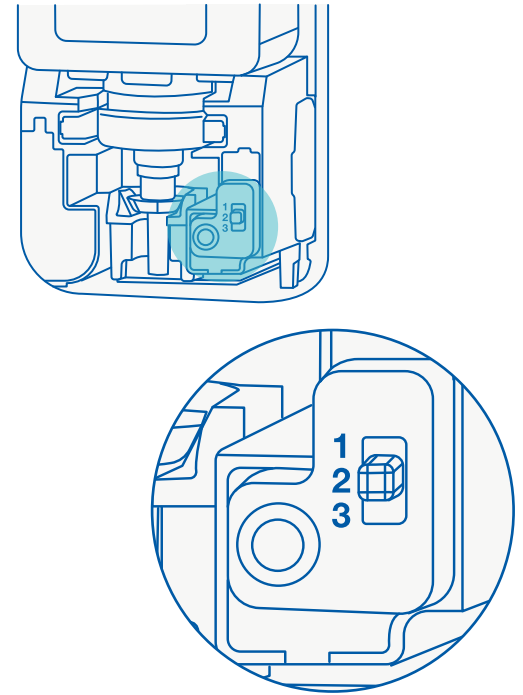

8

Close dispenser cover and activate until product dispenses to ensure pump is primed.

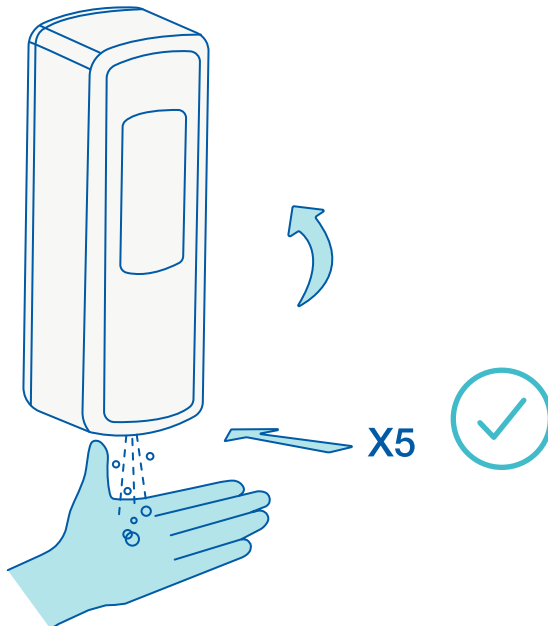

clinell[®]

Touch-free Hand Disinfection Dispenser

Cleaning and Maintenance

Clean exterior surfaces of the dispenser using warm water and mild soap. **DO NOT USE ABRASIVE CLEANSERS.** Dry with a soft cloth.

L.E.D. Light Meaning

1. Solid Red = Cover Open
2. Green = In Use
3. Flashing Red = Low Battery

Cautions

1. It is the installer's responsibility to ensure installation of unit complies with all applicable codes, standards and regulatory requirements.
2. Do not install this dispenser above heat sources or near sources of ignition/flame.
3. Do not install where a failure of the mounting system or dripping of product from hands may cause damage to equipment or create a potential safety hazard.